

### Primary Characteristics

$I_F$	3.0	A
$V_{RRM}$	60	V
$I_{FSM}$	80.0	A
$V_F$	0.60	V

### Features

- Plastic package has Underwriters Laboratory
- Flammability Classification 94V-0
- For surface mounted applications in order to optimize board space
- Low power loss, high efficiency
- High surge capacity
- Acquire quality system certificate : TS16949
- AEC-Q101 qualified
- Lead free in compliance with EU RoHS 2011/65/EU directive
- Green molding compound as per IEC61249 Std. . (Halogen Free)

### Mechanical Data

- Case: SOD-1233HE molded plastic
- Terminals: Solder plated, solderable per MIL-STD-750, Method 2026
- Polarity: Color band denotes cathode end

### Package Outline Dimensions

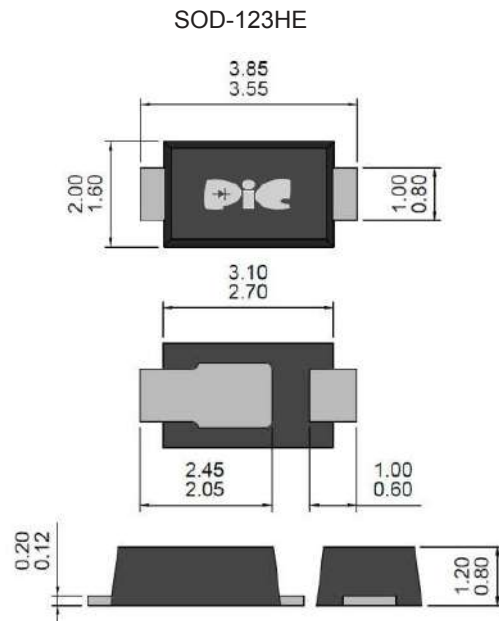

Unit: millimeters

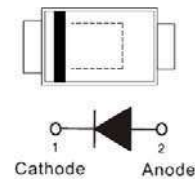

### Maximum Ratings & Electrical Characteristic

Ratings at 25°C ambient temperature unless otherwise specified. Resistive or inductive load.

Parameter	Symbol	SS3060LHE	UNITS
Marking Code	-	ED	-
Maximum Recurrent Peak Reverse Voltage	$V_{RRM}$	60	Volts
Maximum RMS Voltage	$V_{RMS}$	42	Volts
Maximum DC Blocking Voltage	$V_{DC}$	60	Volts
Maximum Average Forward Current	$I_{F(AV)}$	3.0	Amps
Peak Forward Surge Current : 8.3ms single half sine-wave super imposed on rated load	$I_{FSM}$	80	Amps
Maximum Forward Voltage at 3A (Note 1)	$V_F$	0.6	Volts
Maximum DC Reverse Current $T_J=25^\circ\text{C}$	$I_R$	200	$\mu\text{A}$
Typical Thermal Resistance (Note 2)	$R_{\theta JL}$ $R_{\theta JA}$	20 105	$^\circ\text{C} / \text{W}$
Operating Junction Temperature Range	$T_J$	-55 to +150	$^\circ\text{C}$
Storage Temperature Range	$T_{STG}$	-55 to +150	$^\circ\text{C}$

Notes: (1) Pulse Test with  $PW = 300\mu\text{sec}$ , 1% Duty Cycle.

(2) Mounted on 50cm<sup>2</sup> FR-4 PCB Board

### Rating & Characteristic Curves

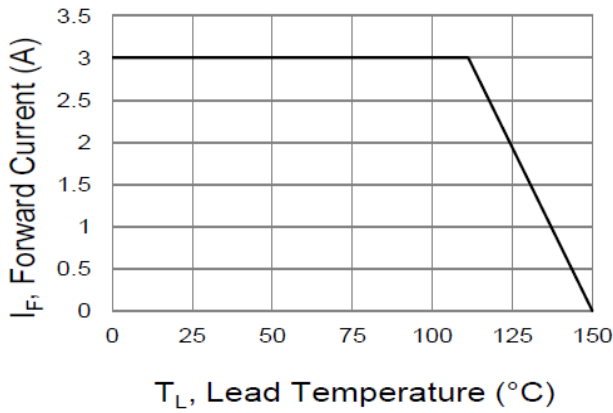

Fig. 1 Forward Current Derating Curve

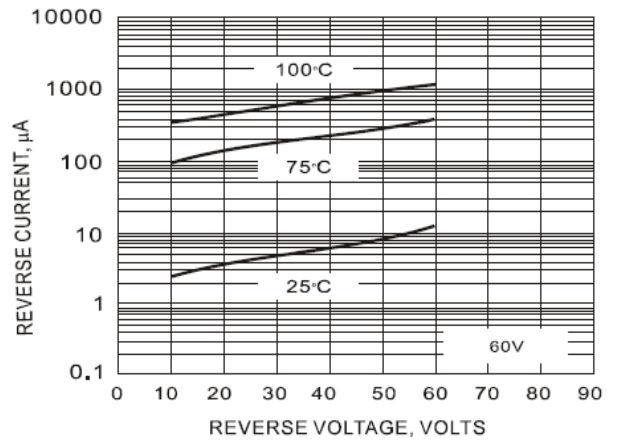

Fig. 2 Typical Reverse Characteristics

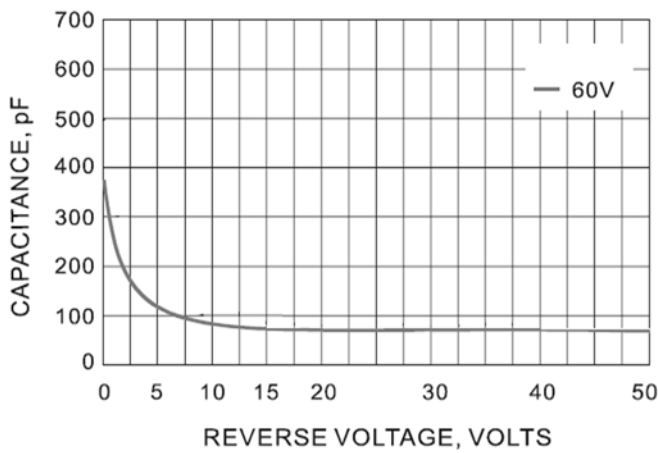

Fig. 4 Typical Junction Capacitance

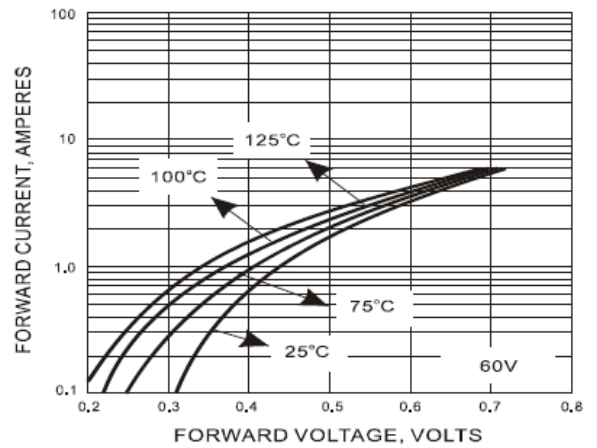

Fig. 6 Typical Instantaneous Forward Characteristics

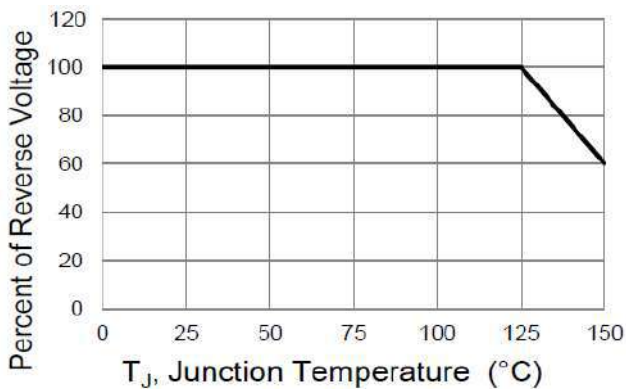
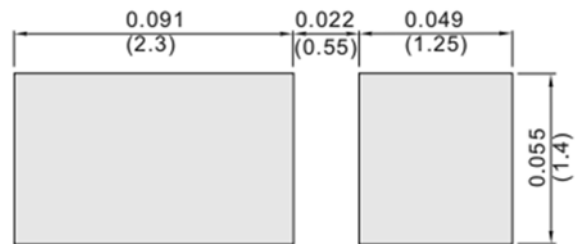

Fig. 7 Operating Temperature Derating

### Pad Layout



Unit: mm

### Packaging Specifications

Package	W (mm)	A (mm)	B (mm)	C (mm)	d1 (mm)	d (mm)	E (mm)	F (mm)	P (mm)	P0 (mm)	P1 (mm)	T (mm)
SOD-123FL	8±0.2	2.00±0.1	3.85±0.1	1.1±0.1	1.0	1.50±0.1	1.75±0.1	3.5±0.05	4±0.1	4±0.05	2±0.05	0.23±0.05
SOD-123HE	8±0.3	2.00±0.1	4.00±0.1	1.45±0.1	1.0	1.55±0.1	1.75±0.1	3.5±0.05	4±0.1	4±0.10	2±0.05	0.23±0.10
SOD-323FL	8±0.2	1.37±0.1	2.75±0.1	0.85±0.1	1.00	1.60±0.1	1.75±0.1	3.50±0.05	4±0.1	4±0.10	-	0.20±0.10
SOD-323HE	8±0.3	1.60±0.1	2.80±0.1	0.95±0.1	1.0	1.50±0.1	1.75±0.1	3.5±0.05	4±0.1	4±0.10	2±0.05	0.23±0.10
SMAF	12±0.3	2.9±0.1	5.5±0.1	2.1±0.1	1.5	1.55±0.1	1.75±0.1	5.5±0.05	4±0.1	4±0.10	2±0.05	0.23±0.10
SMA-S	12±0.2	2.65±0.1	5.25±0.1	1.35±0.1	1.0	1.55±0.1	1.75±0.1	5.5±0.05	4±0.1	4±0.05	2±0.05	0.23±0.10
SMA-HE	12±0.2	2.65±0.1	5.25±0.1	1.35±0.1	1.0	1.55±0.1	1.75±0.1	5.5±0.05	4±0.1	4±0.05	2±0.05	0.23±0.10

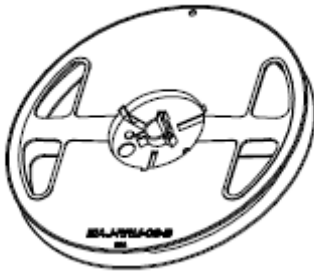
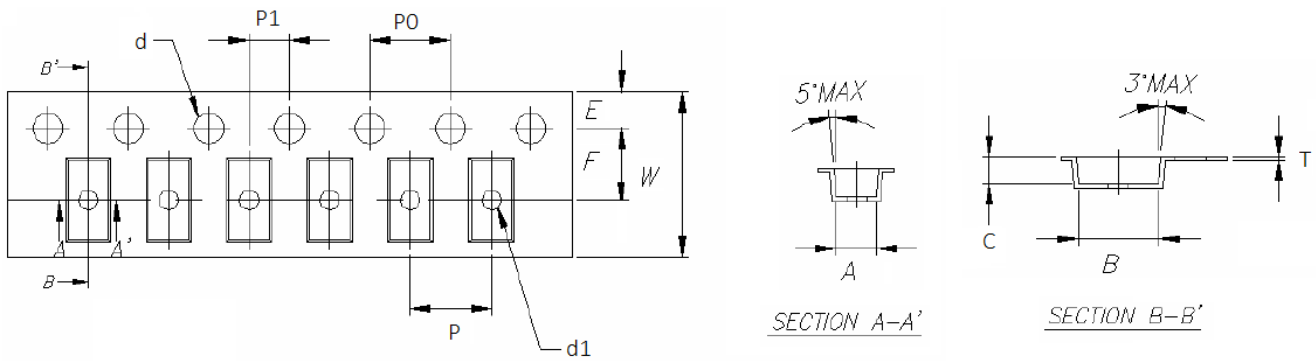

Package	D (max.) (mm)	D1 (min.) (mm)	D2 (mm)	G (min.) (mm)	W1 (min.) (mm)
SOD-123FL	178	50.0	13.0±0.2	8.4	11.4
SOD-123HE	178	50.0	13.0±0.2	8.4	11.4
SOD-323FL	178	50.2	13.0±0.2	8.0	11.5
SOD-323HE	178	50.0	13.0±0.2	8.4	11.4
SMAF	178	50.0	13.0±0.2	12.4	18.0
	330	50.0	13.0±0.2	12.4	18.0
SMA-S	178	50.0	13.0±0.2	12.4	18.0
SMA-HE	178	50.0	13.0±0.2	12.4	18.0

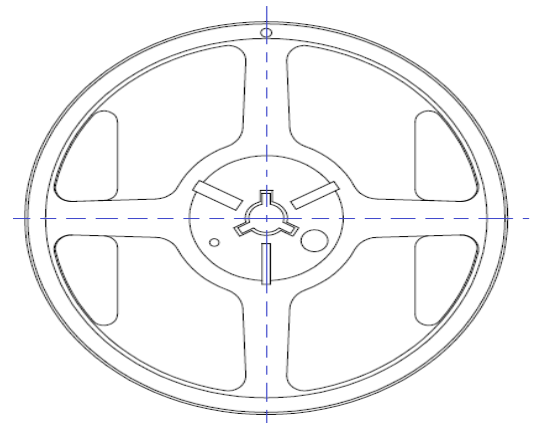
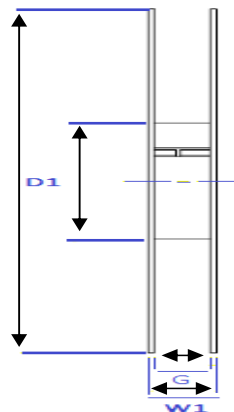
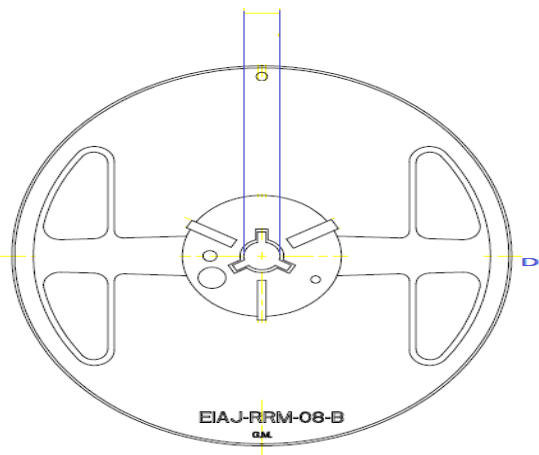

### Recommend IR Reflow Soldering Thermal Profile

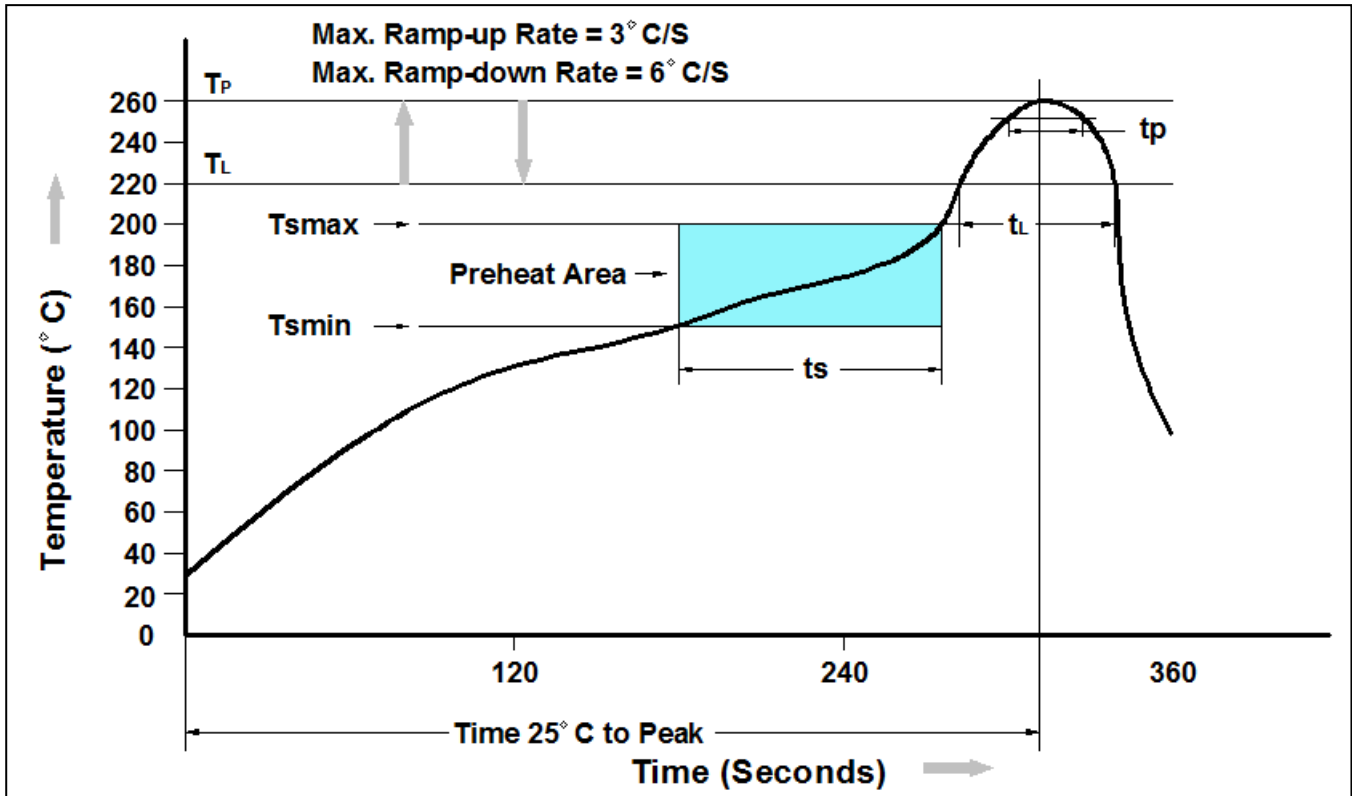

Profile Feature	Pb-Free Assembly Profile
Temperature Min. (T Amin)	150°C
Temperature Max. (Tsmax)	200°C
Time (ts) from (T Amin to Tsmax)	60-120 seconds
Average Ramp-up Rate (tL to tP)	3°C/second max.
Liquidous Temperature (TL)	217°C
Time (tL) Maintained Above (TL)	60 – 150 seconds
Peak Temperature	260°C +0°C / -5°C
Time (tp) within 5°C of actual Peak Temperature	30 seconds
Ramp-down Rate (TP to TL)	6°C/second max
Time 25°C to Peak Temperature	8 minutes max.

### Ordering Information

Part Number	Description	Quantity
SS3060LHE	SOD-123HE Reel	3000 pcs

## **DISCLAIMER**

- The information in this document and any product described herein are subject to change without notice and should not be construed as a commitment by Paceleader, Paceleader reserve the right to make changes to the information in this document.
- Though Paceleader make effort to improve product quality and reliability, Product can malfunction and fail due to their inherent electrical sensitivity and vulnerability to physical stress, it is the responsibility of the customer, when utilizing Paceleader products, to comply with the standards of safety in making a safe design for entire system and to avoid situation in which a malfunction or failure., In developing a new designs, customer should ensure that the device which shown in this documents are used within specified operating ranges.
- The information contained herein is presented only as a guide for the applications of our products. No responsibility is assumed by Paceleader for any infringements of patents or other rights of the third parties which may result from its use.