

➤ General Description

The PAE2471P6 is an Uni-directional TVS diode, utilizing leading monolithic silicon technology to provide fast re-sponse time and low ESD clamping voltage, making this device an ideal solution for protecting voltage sensitive data and power line. The PAE2471P6 complies with the IEC 61000-4-2 (ESD) with $\pm 30\text{kV}$ air and $\pm 30\text{kV}$ contact discharge. It is assembled into an ultra-small 1.6x1.0x0.5mm lead-free DFN package. The small size and high ESD surge protection make PAE2471P6 an ideal choice to protect cell phone, digital cameras, audio play-ers and many other portable applications.

➤ Feature

- Small package: 1.6x1.0x0.5mm
- Protects one data or power line
- Operating Voltage: 24V
- High peak pulse current capability
- Ultra low clamping voltage
- 2-pin leadless package
- Complies with following standards:
 - IEC 61000-4-2 (ESD) immunity test
 - Air discharge: $\pm 30\text{kV}$
 - Contact discharge: $\pm 30\text{kV}$
 - IEC 61000-4-5 (Lightning) 25-150A(8/20 μs)
- RoHS Compliant

➤ DFN1610-2

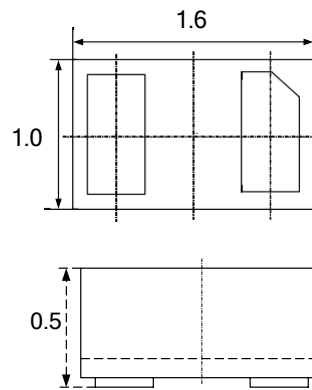

Package Dimensions

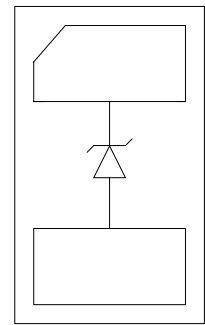

Circuit and Pin Schematic

➤ Mechanical Characteristics

- Package: DFN1610-2
- Case Material: “Green” Molding Compound.
- Moisture Sensitivity: Level 3 per J-STD-020
- Terminal Connections: See Diagram Below

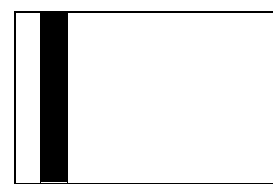

Bar denotes Cathode

➤ Application

- Mobile Phones and Accessories
- Battery Protection
- USB VBus
- Power Line Protection
- Hand Held Portable Applications

➤ **Maximum Ratings (T_A=25°C Unless otherwise specified)**

| Parameter | Symbol | Value | Unit |
|---------------------------------|------------------|-------------|------|
| Peak Pulse Power (8/20μs) | P _{pk} | 1875 | W |
| ESD per IEC 61000-4-2 (Air) | V _{ESD} | ±30 | kV |
| ESD per IEC 61000-4-2 (Contact) | | ±30 | |
| Operating Temperature Range | T _J | -55 to +125 | °C |
| Storage Temperature Range | T _{stg} | -55 to +150 | °C |

➤ **Electrical Characteristics (T_A=25°C Unless otherwise specified)**

| Parameter | Symbol | Min | Typ | Max | Unit | Test Condition |
|-------------------------|------------------|------|-----|------|------|--|
| Reverse Working Voltage | V _{RWM} | | | 24 | V | |
| Breakdown Voltage | V _{BR} | 26.7 | | | V | I _T = 1mA |
| Reverse Leakage Current | I _R | | | 0.1 | μA | V _{RWM} = 24V |
| Forward Voltage | V _F | | | 1.2 | V | I _F = 10mA |
| Peak Pulse Current | I _{PP} | | | 35 | A | t _p = 8/20μs |
| Clamping Voltage | V _C | | | 42 | V | I _{PP} = 10A (8 x 20μs pulse) |
| Clamping Voltage | V _C | | | 53.5 | V | I _{PP} = 35A (8 x 20μs pulse) |
| Junction Capacitance | C _J | | | 200 | pF | V _R = 0V, f = 1MHz |

➤ Typical Characteristics

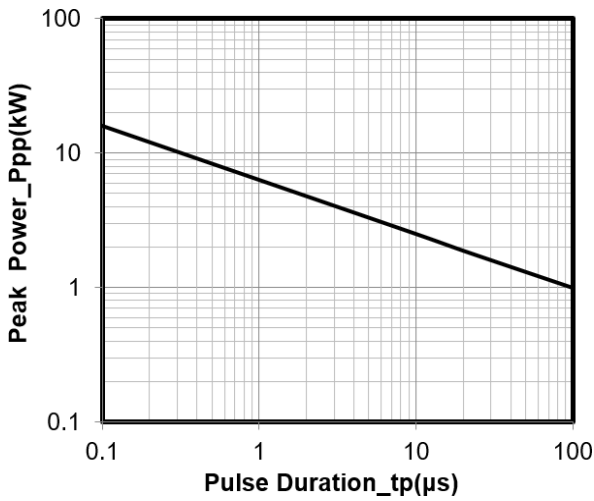

Junction Capacitance vs. Reverse Voltage

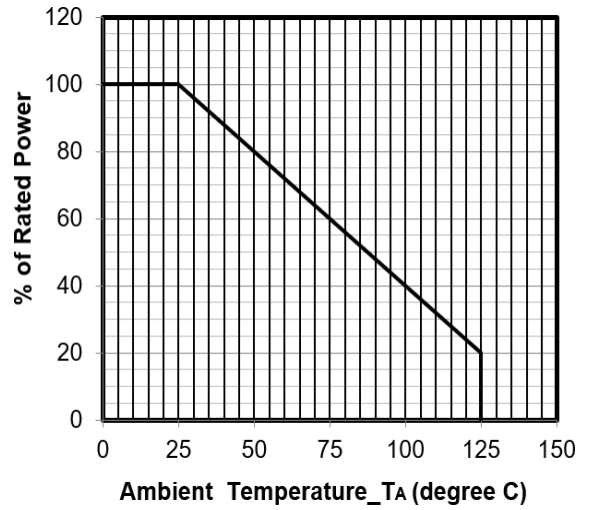

Power Derating Curve

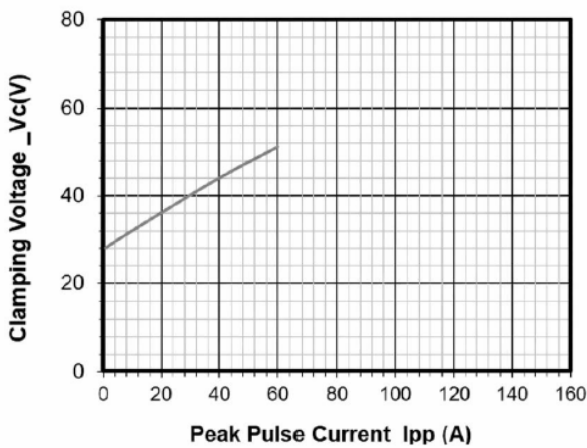

Clamping Voltage vs. Peak Pulse Current ($t_p = 8/20\mu$ s)

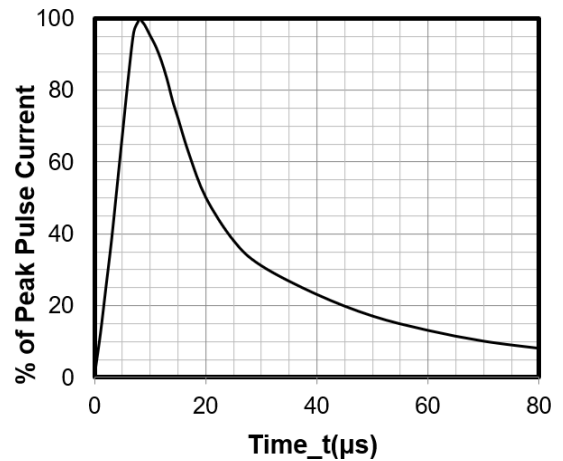

8 X 20 μ s Pulse Waveform

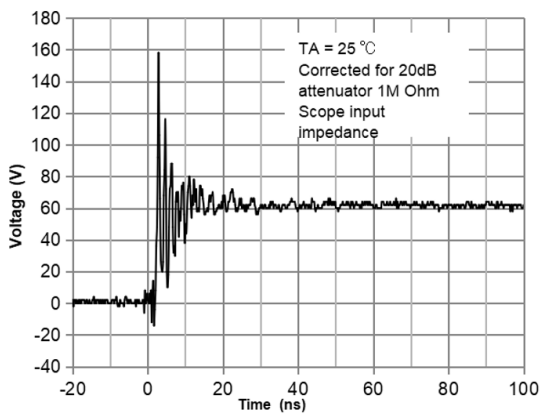

ESD Clamping Voltage
8 kV Contact per IEC61000-4-2

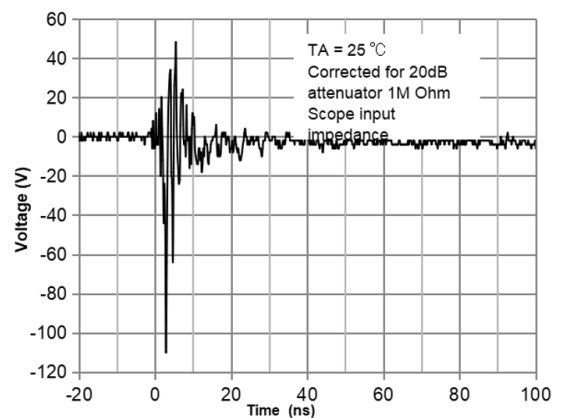

ESD Clamping Voltage
-8 kV Contact per IEC61000-4-2

➤ Recommmend IR Reflow Soldering Thermal Profile

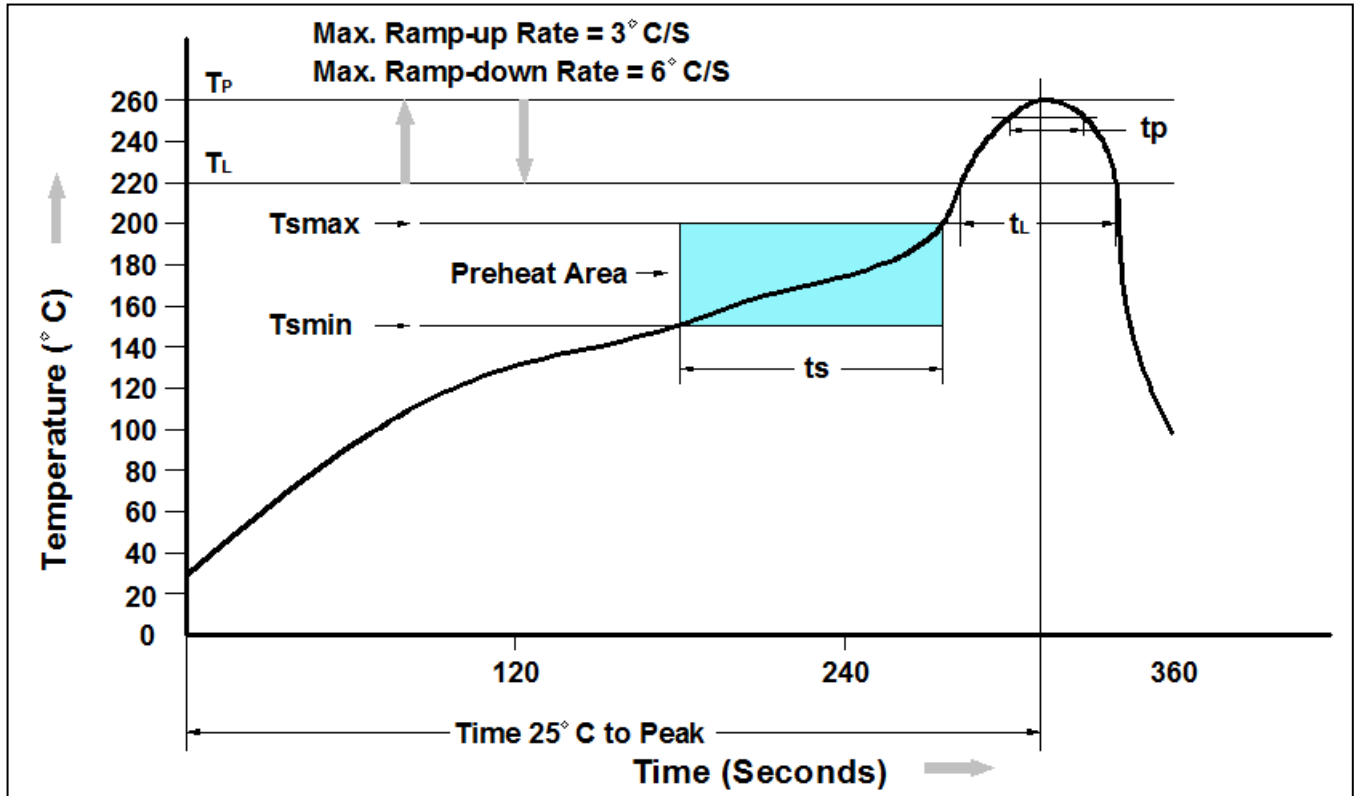

| Profile Feature | Pb-Free Assembly Profile |
|---|--------------------------|
| Temperature Min. (T Amin) | 150°C |
| Temperature Max. (Tsmax) | 200°C |
| Time (ts) from (T Amin to Tsmax) | 60-120 seconds |
| Average Ramp-up Rate (tL to tP) | 3°C/second max. |
| Liquidous Temperature (TL) | 217°C |
| Time (tL) Maintained Above (TL) | 60 – 150 seconds |
| Peak Temperature | 260°C +0°C / -5°C |
| Time (tP) within 5°C of actual Peak Temperature | 30 seconds |
| Ramp-down Rate (TP to TL) | 6°C/second max |
| Time 25°C to Peak Temperature | 8 minutes max. |

➤ Package Information (DFN1610-2)

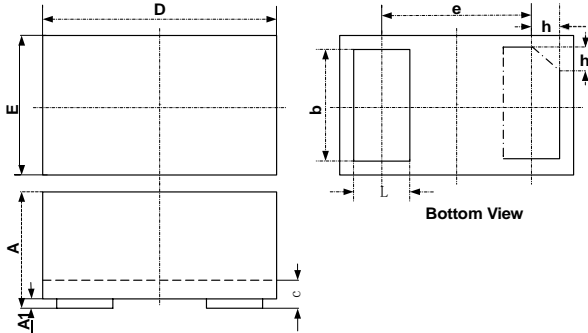

| SYM | DIMENSIONS | | | | | |
|-----|-------------|------|------|-----------|-------|-------|
| | MILLIMETERS | | | INCHES | | |
| | MIN | NOM | MAX | MIN | NOM | MAX |
| A | 0.45 | 0.50 | 0.55 | 0.018 | 0.020 | 0.022 |
| A1 | 0.00 | 0.02 | 0.05 | 0.000 | 0.001 | 0.002 |
| b | 0.75 | 0.80 | 0.85 | 0.030 | 0.032 | 0.034 |
| c | 0.10 | 0.15 | 0.20 | 0.004 | 0.006 | 0.008 |
| D | 1.55 | 1.60 | 1.65 | 0.062 | 0.064 | 0.066 |
| e | 1.10 BSC | | | 0.044 BSC | | |
| E | 0.95 | 1.00 | 1.05 | 0.038 | 0.040 | 0.042 |
| L | 0.35 | 0.40 | 0.45 | 0.014 | 0.016 | 0.018 |
| h | 0.15 | 0.20 | 0.25 | 0.006 | 0.008 | 0.010 |

Suggested Land Pattern

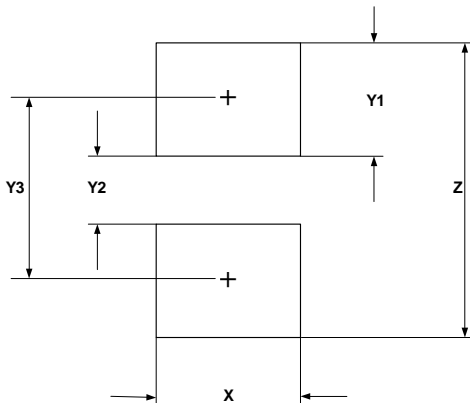

| SYM | DIMENSIONS | |
|-----|-------------|--------|
| | MILLIMETERS | INCHES |
| X | 1.00 | 0.040 |
| Y1 | 0.62 | 0.025 |
| Y2 | 0.60 | 0.024 |
| Y3 | 1.22 | 0.049 |
| Z | 1.85 | 0.074 |

➤ Ordering Information

| Part Number | Description | Quantity |
|-------------|------------------|----------|
| PAE2471P6 | DFN1610-2 / Reel | 3000 pcs |

DISCLAIMER

- The information in this document and any product described herein are subject to change without notice and should not be construed as a commitment by Paceleader, Paceleader reserve the right to make changes to the information in this document.
- Though Paceleader make effort to improve product quality and reliability, Product can malfunction and fail due to their inherent electrical sensitivity and vulnerability to physical stress, it is the responsibility of the customer, when utilizing Paceleader products, to comply with the standards of safety in making a safe design for entire system and to avoid situation in which a malfunction or failure., In developing a new designs, customer should ensure that the device which shown in this documents are used within specified operating ranges.
- The information contained herein is presented only as a guide for the applications of our products. No responsibility is assumed by Paceleader for any infringements of patents or other rights of the third parties which may result from its use.